

# 8600 EMF SERIES



Each (HO) hold open unit contains a door closer and track assembly with hold open electromagnet. The unit can be connected directly to a fire control panel.

1. Read entire instruction sheet prior to installation and refer to NFPA 72E. Standards may be obtained from THE NATIONAL FIRE PROTECTION ASSOCIATION, Batterymarch Park, Quincy, MA., 02269.
2. Reference unit carton for mounting style and voltage.
3. Prepare door and frame for fasteners using the appropriate template. Mark, drill and tap holes as indicated. If surface wiring is used, omit 7/8" hole for wire access.

1 Install closer to door.

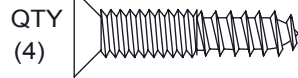

8600T AND 8600DE

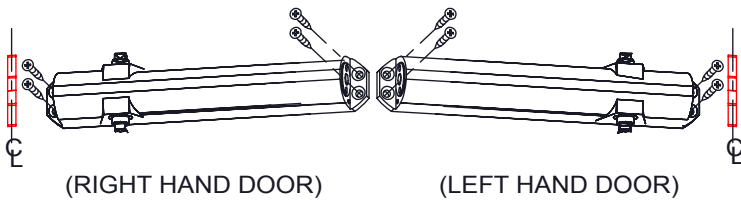

2 Remove (1) wire access plug according to the installation type. Any access hole can be used for surface wiring installations.

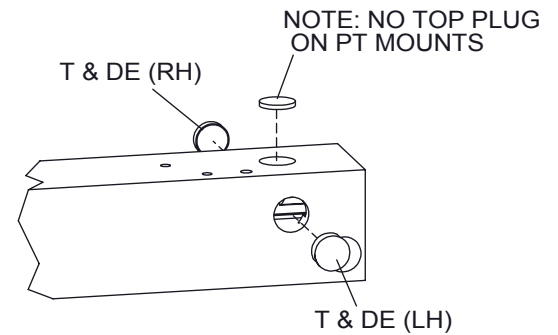

NOTE: Three access wire holes on optional surface wired units only.

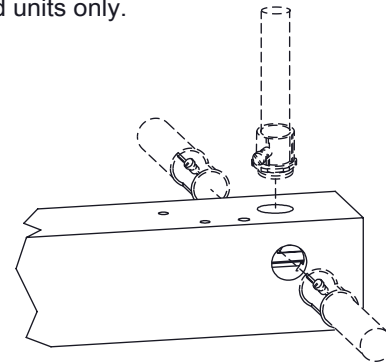

8600PT

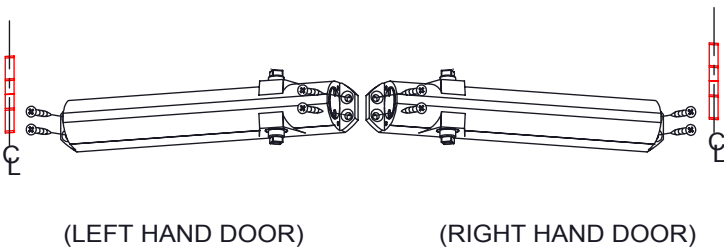

3 Install track to frame.

8600T and 8600DE

Install with wire access plugs toward latch edge of door using (2) 1/4-20 x 2" metal or (2) No. 14 x 2-3/4" wood screws. Route wires from frame through appropriate wire access hole in track, being careful not to pinch wires during installation.

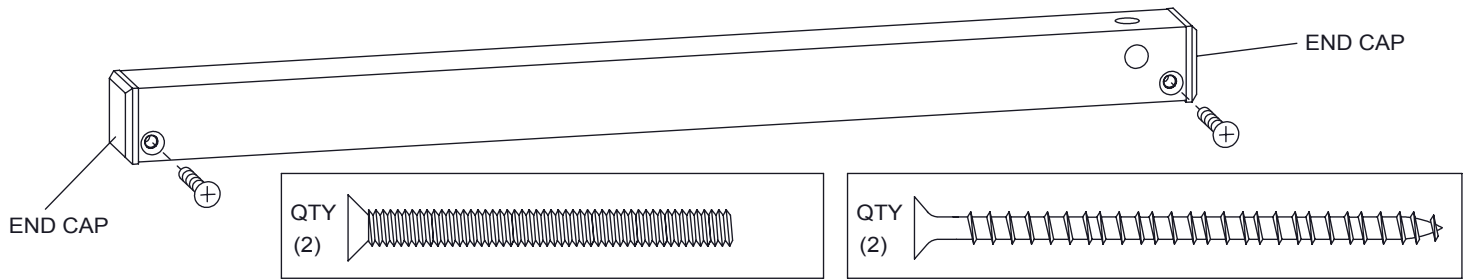

Install PT track to soffit with wire access plugs toward hinge. Install with (1) 1/4-20 x 1-1/4" combo screw and (1) 1/4-20 x 2" metal or No. (1) 14 x 2-3/4" wood screw as shown. Route wires from frame through appropriate wire access hole in track, being careful not to pinch wires during installation. ( DO NOT INSTALL END CAP ON HINGE SIDE IN THIS STEP)

8600PT

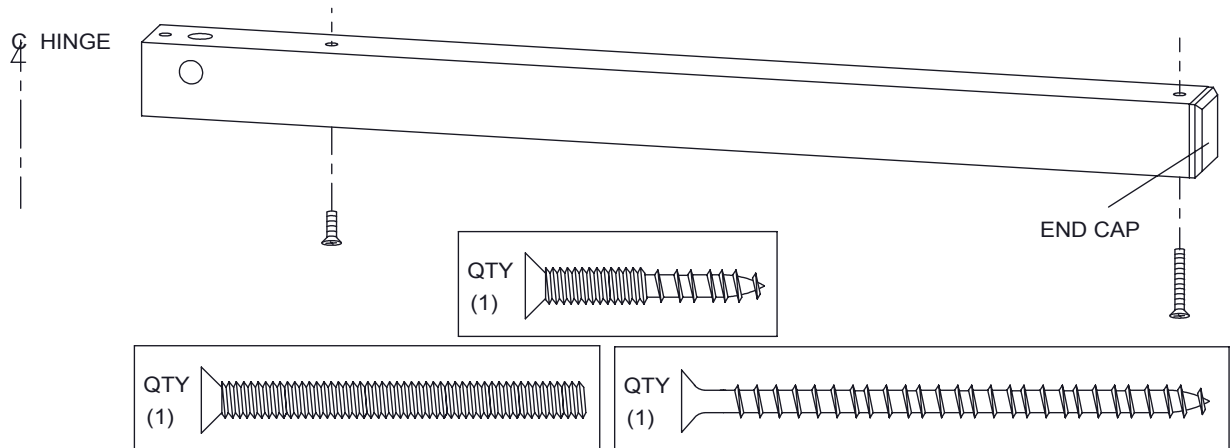

4 Slide wiring connection cover to allow access to wire connections.

Determine power supply and unit voltage type: 24VAC/24VDC. CAUTION!!! DO NOT CONNECT 120VAC TO A 24 VOLT UNIT TYPE. Connect power supply wires to terminal block as shown (Terminal Block can be removed for easier access). Return wiring connection cover to cover wire connections.

**CAUTION:**  
Improper voltage to unit, will result in damage to unit and void warranty.

**NOTE:**  
All wiring must comply with national, state and local electrical codes.

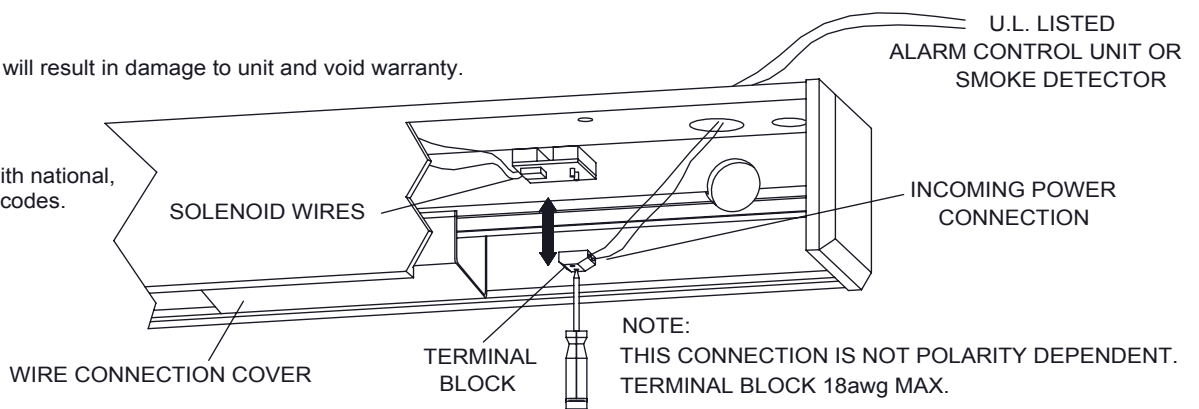

5 8600PT ONLY Insert cover into track, align end cap in end of track.

Install remaining screw as shown using 1/4-20 x 2" metal or No. 14 x 2-3/4" wood screw.

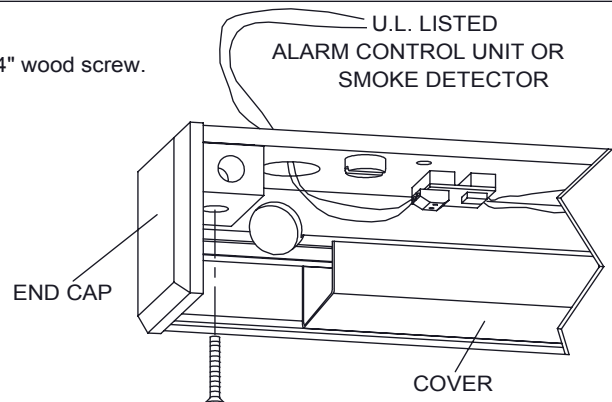
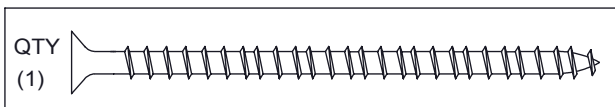
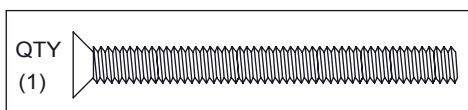

6 Attach main arm to door closer.

8600T Place arm on top pinion as shown @45° angle. Secure with pinion screw and washer.

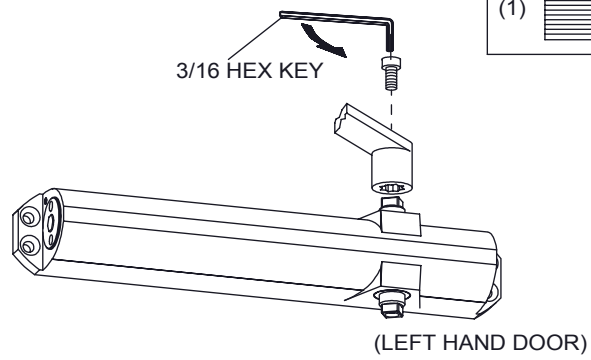
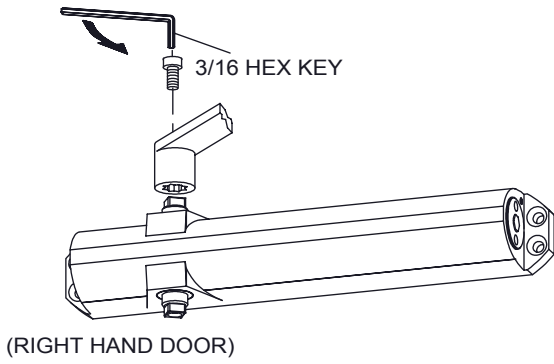
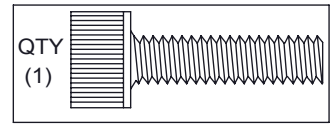

8600DE Place arm on top pinion as shown @45° angle. Secure with pinion screw and washer.

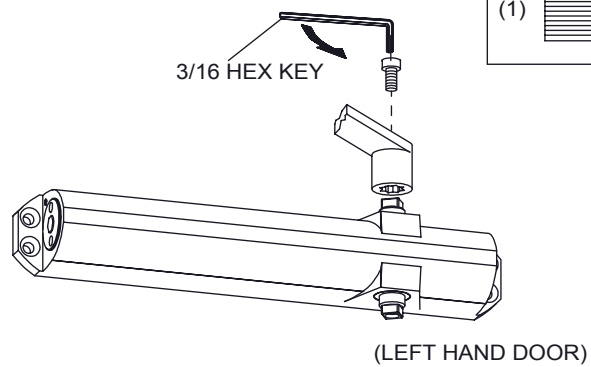
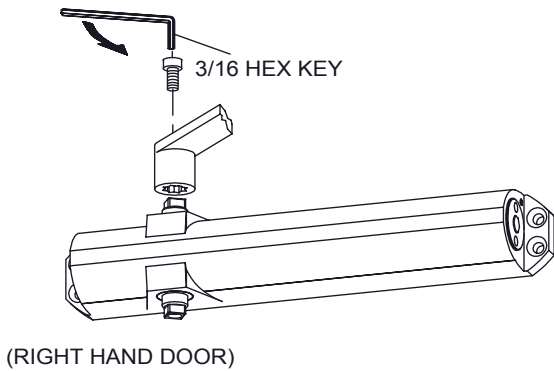
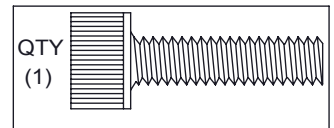

8600PT With door in closed position, rotate bottom pinion 45° with wrench. Place arm on top pinion. Open door and secure with pinion screw and washer.

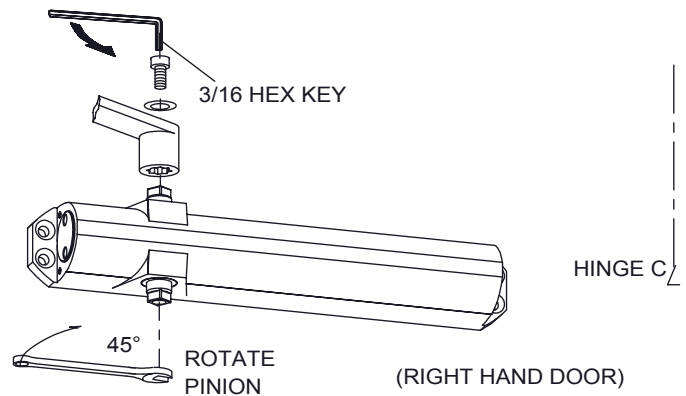
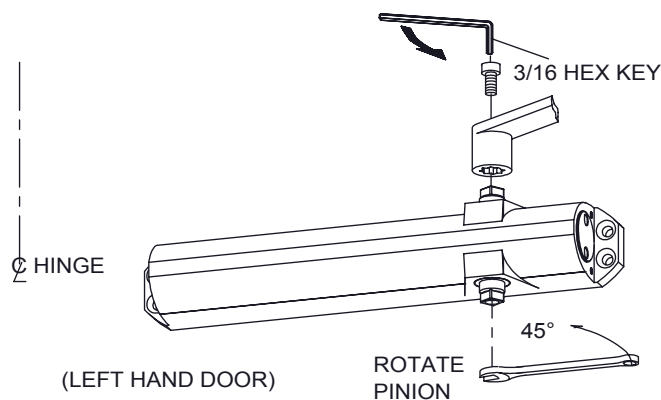
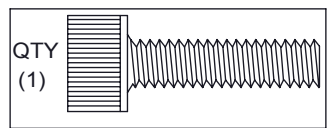

7 Attach arm to slide shoe. Use 3/16 inch hex head wrench.

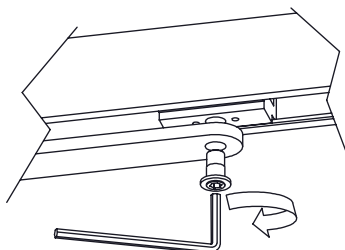

8

# DO NOT REMOVE VALVES

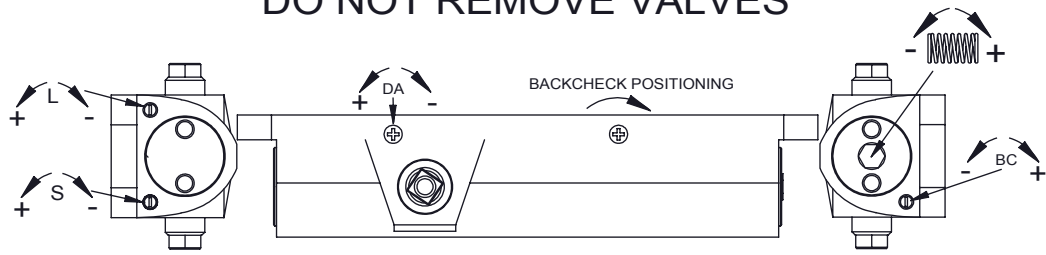

Door Width		Adjuster Full Turns		Spring Size	ULC LABELED UNITS ONLY Max. Door Weight
Exterior	Interior	8616	8656		
-	2'-6" (762)	-11		3	100
2'-6" (762)	3'-0" (914)	0		4	125
3'-0" (914)	3'-6" (1067)	+5	-7	5	150
3'-6" (1067)	4'-0" (1219)	+13	0	6	200

9

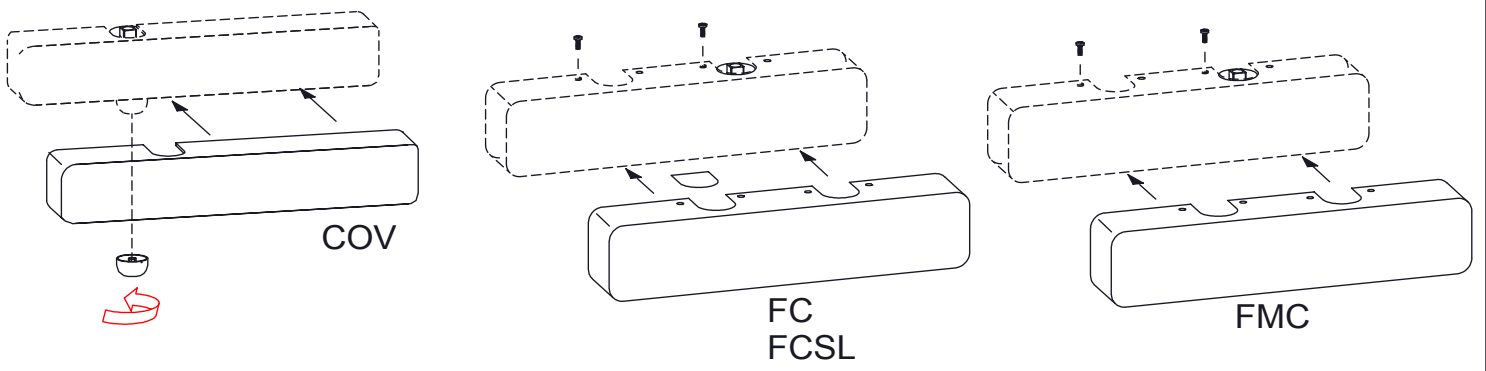

10

Hold open position is preset at approximately 90°. Loosen set screws using 3/32 inch hex wrench. Slide hold open device to desired position. Retighten set screws securely.

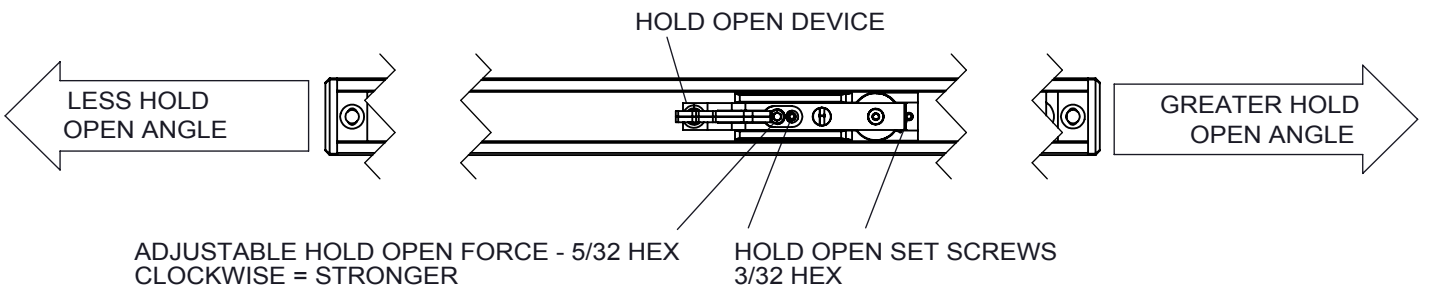

NOTE: POWER MUST BE SUPPLIED TO RESET POSITION.

11 Final installation and test.

1. After installation is completed, recheck all connections. Apply power to units.
2. Open door so slide block engages with hold open assembly.
3. Advise fire officials prior to testing.
4. Activate system into alarm so electromagnets release and doors close.
5. If the closer is used in conjunction with a detected unit, trip the test switch of the main closer detector as explained in the test procedure for that unit. After a short time delay, the hold open electromagnet of both units will release and the doors will close. Resetting the test switch will allow the units to return to standby.

12 An auxiliary door stop (by others) must be installed to limit the maximum degree of door swing. Failure to do so may result in damage to the unit.

13 **IMPORTANT: THE UNIT MUST BE TESTED AFTER THE INSTALLATION, BY THE END USER, TO ASSURE THAT THE DOOR CLOSER UNITS FUNCTION PROPERLY WHEN THE ALARM SYSTEM IS ACTIVATED. THE ENTIRE SYSTEM MUST ALSO BE TESTED PERIODICALLY AFTER THE INITIAL INSTALLATION TEST, IN CONJUNCTION WITH THE TESTING OF THE FIRE ALARM SYSTEM. THE END USER IS ALSO RESPONSIBLE FOR THE ADJUSTMENTS AND MAINTENANCE TO RETAIN THE SYSTEM IN WORKING ORDER.**

14 **OPERATION**

**NORMAL-** The closer unit's electromagnet will be energized across a normally closed alarm contact applying, 24VDC/24VAC power supply based on unit voltage.

**FIRE ALARM-** When the alarm sounds, the alarm contact will open and interrupt current to the electromagnet which releases the hold open and allows the door closer to shut the door.

**ELECTRICAL SPECIFICATION**

Voltage input- 24VDC +10% -15%  
24VAC +10% -15%

Maximum input current- 24VDC 166mA  
24VAC 166mA

